



Electric Vehicle Transportation Center

Current State-of-the-Art of EV Chargers

**Dr. Volker Schwarzer,
Dr. Reza Ghorbani
Department of Mechanical Engineering**

for
Hawaii Natural Energy Institute,
University of Hawaii at Manoa
1680 East West Road, POST 109
Honolulu, HI 96822
E-mail: volkers@hawaii.edu

Submitted to:

Dr. David Block
Florida Solar Energy Center
University of Central Florida
1679 Clearlake Road
Cocoa, FL 32922
E-mail: block@fsec.ucf.edu

Purchase Order Number: 291166
Report Number: HNEI-01-15
February, 2015

The contents of this report reflect the views of the authors, who are responsible for the facts and the accuracy of the information presented herein. This document is a project report issued and disseminated under the sponsorship of the U.S. Department of Transportation's University Transportation Centers Program. The U.S. Government assumes no liability for the contents or use thereof.

Current State-of-the-Art of EV Chargers

Volker Schwarzer, Reza Ghorbani
February 2015

1. Abstract

Recent reports of utility providers have shown that under certain circumstances the integration of renewable energy sources might cause damaging Transient Over-Voltages (TOV) in the power grid. With the rising availability of electric vehicle (EV) charging stations in residential neighborhoods, the potential of EV batteries for TOV reduction is being examined. This report analyses the current state-of-the-art EV charger technology with respect to utilized charging technologies and their capabilities to mitigate over-voltages. Furthermore, power ratings of charging systems, including maximum power influx control and communication strategies, are analyzed. Corresponding time constraints, as well as system response times are also determined.

2. Introduction

As of July 2014, the United States had the largest highway-capable plug-in electric car fleet in the world, with overall sales exceeding 286,000 vehicles (see the Electric Vehicle Transportation Center (EVTC) project at <http://evtc.fsec.ucf.edu/research/project5.html>). Of the 117,538,000 households in the United States in 2010, 0.19% of them possessed an EV of some sort. If EV sales growth remains stable, more than 1% of US households will own an electric car by 2019. Future opportunities and challenges presented by this development for vehicle-to grid (V2G) integration have been thoroughly discussed in the literature [1,2,3,4,5]. Moreover, there are ongoing studies on the capabilities of grid-integrated EVs to perform peak load leveling [6,7,8,9]. It has been proposed that EV batteries could buffer renewable power sources such as wind power by "valley filling" when the demand is low and "peak shaving" during high load periods, thus effectively stabilizing the intermittency of renewable energy sources.

Nevertheless, recent reports of utility providers have shown that under certain circumstances the integration of renewable energy sources might cause damaging transient over-voltages in the grid [10]. TOVs are short, rapid rises in voltage along the electric lines of the grid. Without sufficient mitigation, TOVs can damage utility equipment or personal electric devices of the adjunct households. For example, TOVs can occur when the generated power of a distribution circuit exceeds its load while the circuit is isolated. Isolations could be caused by standard procedures of the utility provider such as the switching to a backup circuit, or by failure of protective equipment, i.e. fuse failure.

For the case of photovoltaics (PV) power, several control strategies for PV inverters have been proposed to prevent TOVs from occurring in distribution systems. Reno et al. suggested to adjust the power factor according to previous experience of when high voltages from the solar output or from the load typically occur during the day [11]. Other

authors have studied the implementation and capabilities of Volt/Var control [12,13,14]. Furthermore, various optimal control strategies for reactive power have been studied [15,16,17,18]. However, the disadvantage of inverter-based TOV control strategies is that each inverter has to be equipped with a separate control module. Existing inverters would have to be upgraded or replaced. Additionally, TOVs can not only be caused but also not be prevented if just one inverter controller would fail.

Recent reports of utility providers have shown that under certain circumstances the integration of renewable energy sources might cause damaging TOVs in the grid, and it can be expected that EVs connected to the grid via commercial- or home charging stations might be a typical occurrence in many neighborhoods in the near future. On top of peak load leveling, grid-connected EV batteries might be capable of absorbing TOVs if they cannot be prevented in the first place. Charging stations using converter technologies are commonly used as the interface between the EV batteries and the utility grid. If specially designed for the task, they might be able to solve the TOV related utility problems for a better and safer integration of household PVs into the grid. TOVs might occur instantaneously without previous warning signs. To prevent damage to utility or household equipment, a power absorption system should be capable of identifying and reacting to TOVs as quickly as possible while absorbing all of the extra power.

EV charging technology is still in its early footsteps. A large variety of technologies exists and are used depending on various properties, local norms, and regulations:

- EV battery type, capacity, and rating
- international charging standards (, i.e. Japanese-developed CHAdeMO standard, Society of Automotive Engineers (SAE) International J1772 Combo standard, or IEC 61851-1:2010 conductive charging standard)
- typical EV usage pattern (short vs. long commutes, single vs. multiple daily commutes, slow overnight vs. fast charging, etc.)
- grid properties (voltage, phase, maximum grid current, etc.)
- budget constraints

To identify potentials of EV batteries for TOV reduction, this reports analyses the current state-of-the-art EV charger technology with respect to:

- utilized charging technology and their capabilities to mitigate over-voltages
- power rating of charging systems including maximum power influx
- control and communication strategies and corresponding time constraints
- system response times
- limitations induced by safety regulations and technical standards

3. Battery Charger Technology

In order to understand the electrical requirements for battery charging and the grid, PV power production is used as the example. For PV in domestic applications, electrical sub-circuits typically range from 0.5-20kW in the US. Thus, according to [10], any proposed solution for TOV mitigation needs to fulfill the following requirements:

- the TOV mitigation should be effective within a duration of 1 cycle (1/60th of a second) or less
- the mitigation should be initiated when the voltage is 120% above nominal voltage (144V in the US)

Hence, all system components of the charging infrastructure (grid to battery) should be capable of accomplishing the above tasks while obeying safety regulations. This includes sensors, controllers, communication devices and protocols. The following sections take a top down approach to analyzing EV charger technology, starting from system level and ending with single components and controllers.

3.1. Categorization of EV Charging Stations

The Society of Automotive Engineers (SAE) and the International Electrotechnical Commission (IEC) introduced approaches to categorize charging stations by their power level and their corresponding charging modes.

3.1.1. SAE's Categorization of EV Charging According to Power Levels

The "SAE Surface Vehicle Recommended Practice J1772, SAE Electric Vehicle Conductive Charge Coupler" (short: SAE J1772) is a standard for electrical connectors for electric vehicles maintained by the Society of Automotive Engineers [19]. It covers all physical aspects of the conductive charge technology, such as electrical specifications, communication protocols, and performance requirements. The SAE J1772 distinguishes charging stations by three different power levels. Within these levels there is a large degree of freedom for component configurations and operational options to accommodate different existing power grid standards.

Table 2.1 gives an overview of the technical specification, safety configurations, couplers and typical charging times of each category.

Table 2.1: Categorization of charging levels according to SAE J1772 (2009)

	Level 1 Charging	Level 2 Charging	DC Fast Charge (Level 3)
Voltage	Single Phase AC, 120V	Single or Three Phase AC, 240V	Direct Current DC, 200-600V
Peak Current	16A	80A (since 2009)	400A
Maximum Power	1.92kW	19.2kW	240kW
Charging Station	grounded receptacles for domestic application, domestic socket outlet, or Level 1 charging station	Level 2 charging station, cable permanently fixed to charging station	Level 3 charging station
Coupler/Connector	domestic power cord, SAE J1772	IEC 62196-2 Type 2, IEC 62196-2 Type 3, etc.	SAE J1772 Hybrid Coupler, CHAdeMO, etc.
Charge times	6h (PHEV) to 24h (BEV)	2h (PHEV) to 8h (BEV)	10min (PHEV) to 30min (BEV)

Level 1 Charging

Level 1 charging utilizes a standard domestic 120V AC outlet protected by a circuit breaker with a ground fault interrupter (GFI) [20]. Installation costs typically range from several hundred to a few thousand US dollar. Power Factor Correction (PFC), AC/DC conversion, DC/DC boost conversion, battery management, and various filtering functions are carried out within the charger [21]. Best applications include low-range EVs. Mid-range EVs and PHEVs can also be charged with Level 1 chargers using a special power cord with a standard domestic plug on the charging side and a SAE J1772 connector on the vehicle side.

Figure 2.1 shows a schematic diagram of a typical Level 1 EV charger setup [21]. For a domestic outlet with 16A and 120V, the maximum delivered power is approximately 2kW. Charging times typically vary between 6 to 24 hours, depending on the vehicle. Hence, Level 1 charging stations are usually used in locations where the vehicle is parked for long periods of time, such as personal garages for overnight charging, long-term parking in airports, or at workplaces.

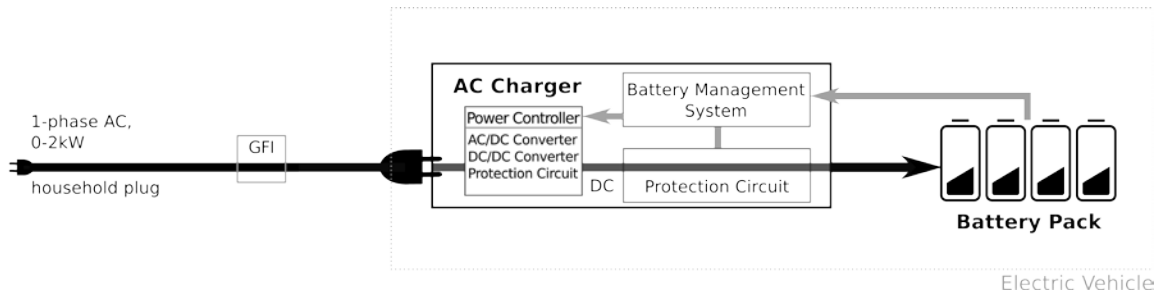

Figure 2.1: Level 1 EV charging setup

Level 2 Charging

A dedicated single- or three-phase 208-240V AC circuit is generally used for Level 2 charging. The charging station is protected by a circuit breaker and GFI. Again, PFC, AC/DC conversion, DC/DC boost conversion, battery management, and various filtering functions are carried out within the charger. A safety interlock and communication interface between the charging station and the on-board EV charger is established via the coupler. With a peak current of 80A (since 2009), the maximum delivered power can be up to 20kW. The charging cables are permanently fixed to the charging station. Figure 2.2 illustrates the setup of a Level 2 EV charging station. Usually, charging times are between 2 to 8 hours, depending on the battery power requirements. Thus, Level 2 charging stations are usually installed in locations where the EV operator parks for a shorter period of time, i.e. while shopping, or attending a meeting. However, Level 2 stations can also be installed at private homes provided a dedicated circuit is available.

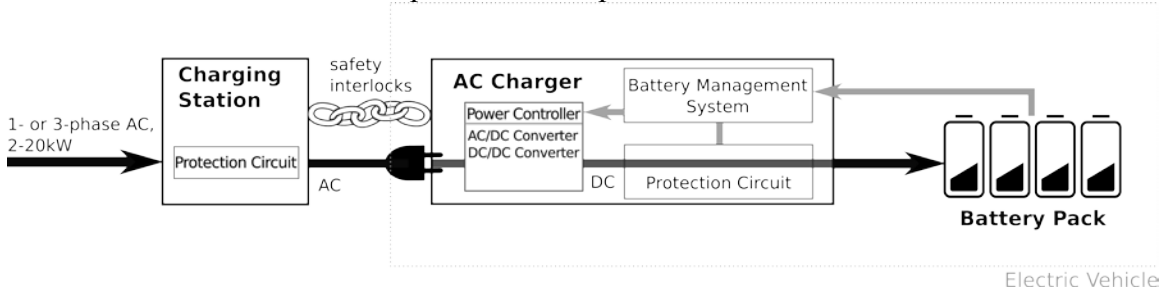

Figure 2.2: Level 2 EV charging setup

Level 3 Charging

A maximum power of 240kW can be delivered with Level 3 chargers (also referred to as Direct Current DC charging). This can be achieved with very high currents of up to 400A and 600V DC on a dedicated circuit with high-amperage connections to the grid. The charging station is protected by various safety measurements and typically incorporates PFC, AC/DC conversion, and DC/DC boost conversion to supply variable DC directly to the EV charger. The on-board charger features the Battery Management System (BMS), which communicates to the charging station via CAN bus. The charging cable is fixed to the charging station. Currently, various competing standards for the coupler exist, for example the SAE J1772 Hybrid coupler in the US, the CHAdeMO in Japan, or the IEC 62196 Type 2 Hybrid in Europe.

Figure 2.3 displays a possible setup for a DC charging station. Typical charging times range from 10 to 30min. The comparatively short charging times enable commercial operations of DC fast charging stations similar to gas stations. Lucrative locations might include rest stops, conventional gas stations, or shopping malls.

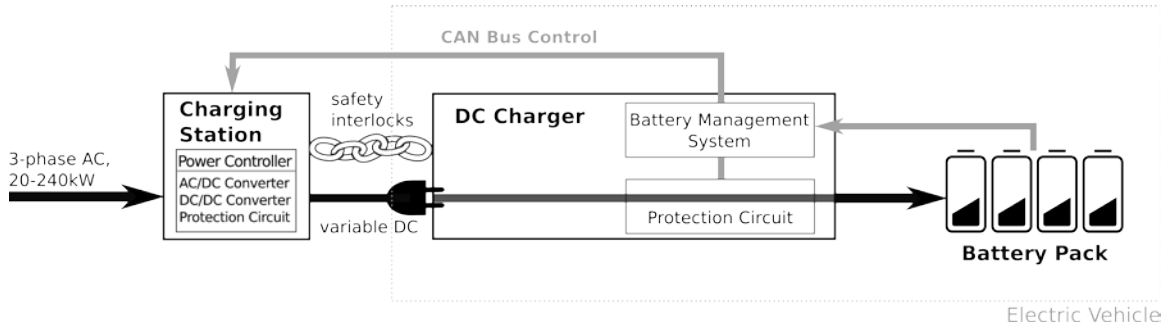

Figure 2.3: Level 3 EV charging setup

3.1.2. IEC's Categorization of EV Charging According to Charging Modes

The charging mode describes the safety communication protocol between the charging station and the EV. IEC 62196 is a standard for plugs, socket-outlets, connectors, inlets and cable assemblies for electric vehicles, intended for use in conductive charging systems which incorporate control means. It references the IEC 61851-1 ("Vehicle Conductive Charging System - Part 1: General requirements") standard, which distinguishes EV charging by the charging mode. Furthermore, the IEC 61851-1 standard complements IEC 62196 by defining pilot signals for flagging the charging requirements by using pulse width modulation (PWM).

Table 2.2 gives an overview of the four charging modes.

Table 2.2: Categorization of charging modes according to IEC 6219

	Mode 1	Mode2	Mode 3	Mode 4
Description	slow charging from a household-type socket-outlet	slow charging from a household-type socket-outlet with an in-cable protection device	slow or fast charging using a specific EV socket-outlet with control and protection function installed	fast charging using an external charger
Voltage	Single Phase AC < 250V or Three Phase AC < 480V	Single Phase AC < 250V or Three Phase AC < 480V	Three Phase AC < 480V	Direct Current DC, 200-600V
Peak Current	16A	32A	250A	400A
Max Power	0-13.3kW	0-26.6kW	184.4kW	240kW
Safety	power and protective earth equipment	power and protective earth equipment (1000Ω resistor between pilot and earthing to break circuit if current on pilot-earth loop is lost), IEC 61851-1 control pin on EV	same as Mode 2, but control and signal pins for both sides of the cable, socket is dead if no vehicle present, pilot pin in the plug on the charger side controls the circuit break	control and signal pins to ensure operation for fast charging comparable to Mode 3
Coupler	non-dedicated household plug	non-dedicated household plug	IEC 62196-2 Type 1-3, SAE J1772	SAE J1772 Hybrid, IEC 62196-2 Type 2 Hybrid, CHAdeMO
Notes	not allowed by national US codes since earthing is not present in all domestic installations	RCD required for protection, control box must be in the plug or within 0.3 metres of the plug	communication port enables integration into smart grid	communication plug enables integration into smart grid and checks compatibility of connected EV

Mode 1 Charging

During Mode 1 charging, the EV is connected to an AC supply network using a non-dedicated household socket. The maximum current does not exceed 16A and the maximum voltage is not larger than 250V for a single-phase AC network, or 480V for a three-phase AC network. Mode 1 requires both, an over-current protection device and protective earth conductors. Figure 2.4 illustrates a mode 1 charging setup proposed by Siemens [23]. A Circuit Breaker (CB) is utilized for over-current protection and a Ground Fault Interrupter (GFI) for disconnecting the circuit whenever the electric current is not

balanced between the energized conductor and the return neutral conductor. The usage of a surge arrester is recommended.

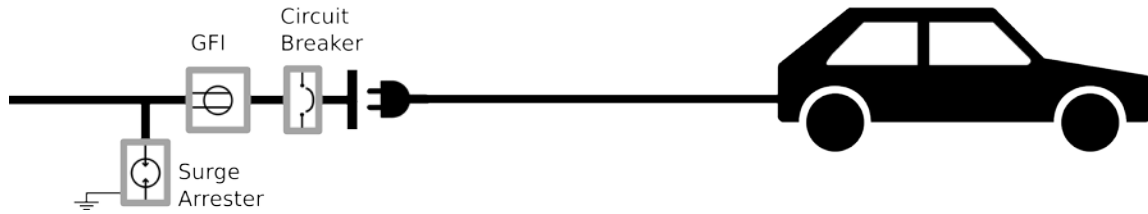

Figure 2.4: Mode 1 EV charging setup recommended by Siemens [23]

IEC 61851-1 does not require the implementation of any control pins for Mode 1 connectors. Mode 1 charging is not permitted in some countries, including the US.

Mode 2 Charging

The connection of an EV to an AC supply network is referred to as Mode 2 charging when the maximum current does not exceed 32A and the maximum voltage is smaller than 250V for single-phase or smaller than 480V for three-phase networks. Mode 2 charging requires over-current protection, protective earth, and a residual current protective device for protection against electric shocks. A charging control system is integrated via an inline module in the charging cable, as illustrated in Figure 2.5. Hence, Mode 2 couplers require a control pin (defined in IEC 61851-1) on the vehicle side. However, the network side of the cable does not require a control pin, since the control system is integrated into the charging cable.

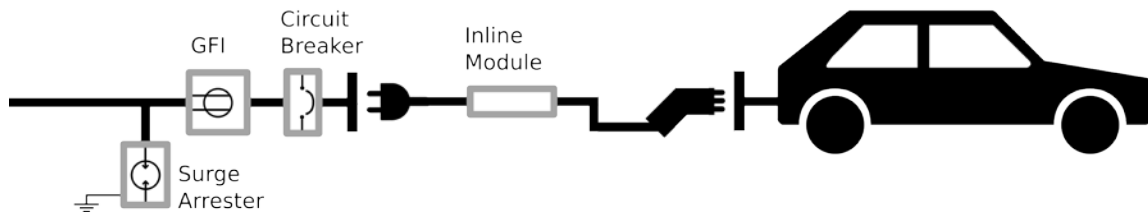

Figure 2.5: Mode 2 EV charging setup recommended by Siemens [23]

Mode 3 Charging

With Mode 3 charging, the EV is connected to a charging installation, which is permanently connected to a single-phase or three-phase AC network. The charging control pilot function is governed via the on-board charger in the EV and the Electric Vehicle Supply Equipment (EVSE) control module in the off-board installation. Figure 2.6 displays a possible setup of a Mode 3 charging station proposed by Siemens. Mode 3 charging requires over-current protection and a Ground Fault Interrupter within the charging station. The usage of a surge arrester is recommended.

IEC 61851-1 demands for the implementation of several control and signal pins into the coupler. A pilot pin in the plug on the charging station side controls the circuit breaker, which deactivates the charging station if no vehicle is connected.

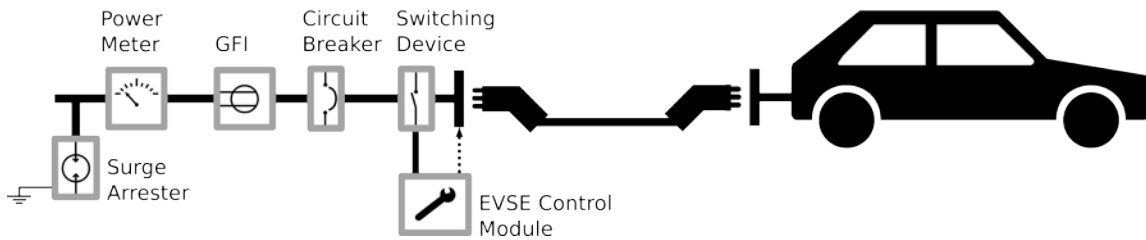

Figure 2.6: Mode 3 EV charging setup recommended by Siemens [23]

Mode 4 Charging

In charging Mode 4, the EV is connected to a single-phase or three-phase AC network with an AC/DC converter. An off-board EV charger is utilized to enable rapid charging. Mode 4 DC fast charging allows currents of up to 400A. The vehicle is connected with an IEC 62196 standardized connector on the vehicle side (all modes possible), and with an IEC 62196 Mode 3 connector on the charging station side. Figure 2.7 illustrates this setup. Mode 4 charging stations have to incorporate AC/DC-sensitive GFIs and separate over-current protection devices for AC and DC. The control and signal pins of a Mode 4 connector are similar to Mode 3 connectors according to IEC 61851-1.

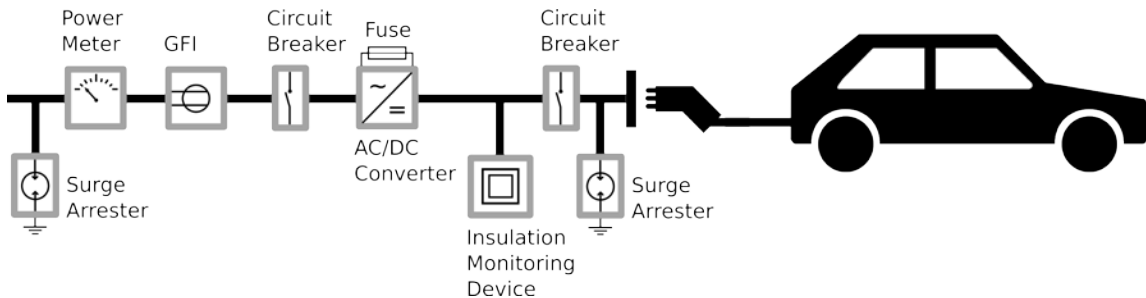

Figure 2.7: Mode 4 EV charging setup recommended by Siemens [23]

3.2. Connector Standards

IEC 62196-1 refers to IEC 60309, which is an international standard from the International Electrotechnical Commission (IEC) for "plugs, socket-outlets and couplers for industrial purposes". While IEC 60309 plugs are still in use for EVs, a number of connection systems have been specifically tailored for EV charging. The IEC 62196-2 standard describes three plug types for connection to AC supply networks. Table 2.3 gives an overview of these plugs and their international usage, as well as international plug standards for DC fast charging.

Table 2.3: International utilization of charging connectors

	US	EU	Japan	China
Single Phase	 <p>SAE J1772</p>	 <p>SAE J1772/IEC 62196-2 Type 1</p>	 <p>SAE J1772</p>	 <p>IEC 62196 Type 2</p>
Single- or Three Phase		 <p>IEC 62196 Type 2</p>  <p>IEC 62196 Type 3</p>		
DC	 <p>SAE J1772 Hybrid</p>	 <p>IEC 62196 Type 2 Hybrid</p>	 <p>CHAdeMo</p>	 <p>GB Standard Mode 3</p>

IEC 62196-2 Type 1

The IEC 62196-2 Type 1 plug is used for single phase vehicle couplers. The SAE J1772-2009 standard was used to define IEC 62196-2 Type 1 connectors. Type 1 plugs have five pins: two pins for single-phase AC, one pin for earthing, one pin for proximity detection, and one pin for the control pilot function (according to IEC 61851-2001 / SAE J1772-2001). IEC 62196 Type 1 couplers are rated for 250V at 32A (80A in the US).

IEC 62196-2 Type

The IEC 62196-2 Type 2 connector has been developed by the manufacturer Mennekes based on IEC 60309 three-phase connectors using additional pins. It can be used for single-phase or three-phase supply networks. It features a smaller diameter of 55mm for easier handling and a flattened side for protection against polarity reversal [25]. IEC 62196 Type 2 couplers are rated for a charging output of up to 43.5 kW and a charging current of up to 63A.

IEC 62196-2 Type 3

Type 3 connectors are single and three phase vehicle coupler with shutters. The EV Plug Alliance proposed two different Type 3 connectors. Type 3a is a derivation of the Italian Scame connector for light vehicles (, i.e. E-Bikes or E-Scooters). IEC 62196 pins are added for single-phase charging. Type 3b incorporates two more pins for three-phase charging. The maximum power is limited to 22kW at 32A for three-phase networks to allow for cheaper plugs and installation costs.

DC Charging Connector

Several plug types for DC charging currently exist:

- The JARI Level-3 DC fast charge connector has been developed by TEPCO in Japan for CHAdeMO. CHAdeMO is a DC fast charging standard delivering up to 62.5kW of high-voltage direct current. The maximum rated current for the JARI Level-3 DC connector is 125A at up to 500V (DC). The JARI specifications are described in the JEVS (Japan Electric Vehicle Standard) G105-1993 standard. Information is transmitted via CAN-bus and analog control lines. This hybrid communication protocol adds extra safety to the system by double checking the digital control system. Furthermore, if the analog signal is lost, an immediate charging operation shut down can be performed, which is not possible for pure digital control.

The CHAdeMO charging sequence is performed in three steps [26], which are:

- I. Charging preparation - EV compatibility check with the charger based on the information transmitted via the CAN-bus. After the connector is established, the charger applies a short-term voltage load to the circuit

to confirm there are no abnormalities such as a short circuit or ground fault.

- II. Start of power supply - the vehicle calculates the current level based on the battery performance and other obtained parameters. The calculated value is submitted to the charger in an interval of 0.1 seconds via CAN-bus.
 - III. End of charging - the vehicle submits zero current signals via CAN-bus to stop the charger. After confirmation, the EV opens the contact and sends prohibit signals to a charger, and the charger confirms that its output current is zero.
- A combo variant of the J1772-2009 connector has been developed by SAE. The combo coupler features extra pins compared to the standard version. EVs using the J1772 combo coupler are capable of being charged at 12A from a regular 110 VAC wall outlet (1.4kW), up to 80A at 240 VAC (19.2kW) or up to 200A at 200-450 VDC (90kW). Power Line Carrier (PLC) technology is integrated to allow communication between the EV and the off-board charger, as well as between the vehicle and the smart grid. No extra pins in the coupler are required for that task.
 - The IEC 62196 Type 2 Hybrid coupler has been introduced in Europe. The coupler is based on the Type 2 AC charger, but features full compatibility with the SAE standards for DC fast charging and PLC technology.
 - The GB/T 20234 Mode 3 charger is used in China for DC fast charging. The GB/T 20234 standard is very similar to the IEC 62196 [27]. It supports single-phase and three-phase AC charging, as well as DC fast charging at up to 400V. The pin layout is similar to the IEC layout. However, differences exist in the functionality. Chinese GB connectors make use of CAN-bus communication, while IEC connector utilize PLC technology. Furthermore, the GB EVSE controls are based on current detection, while IEC uses voltage detection.

3.3. Signaling and Safety Measurements

IEC 61851 introduces and describes the function of the signal pins. All IEC 62196-2 plugs utilize two signal pins, the control pilot pin (CP), and the proximity pilot pin (PP). The signaling protocol was designed for plug- and connection detection, communication between EV and charging station, execution of safety routines, and monitoring. Figure 2.8 shows a schematic diagram of the signaling circuit in a J1772 interface.

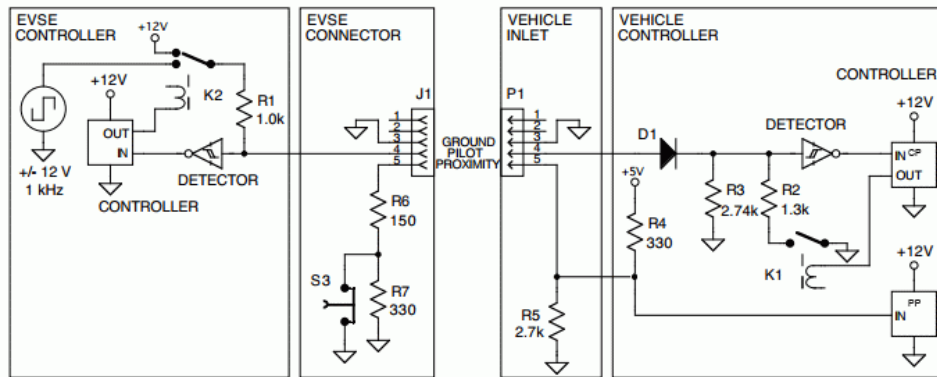

Figure 2.8: Electrical schematic diagram of the signaling circuit in a J1772 interface - source: commons.wikimedia.org/wiki/File:J1772_signaling_circuit.gif, author: DavideAndrea at en.wikipedia, license: CC-BY-SA-3.0

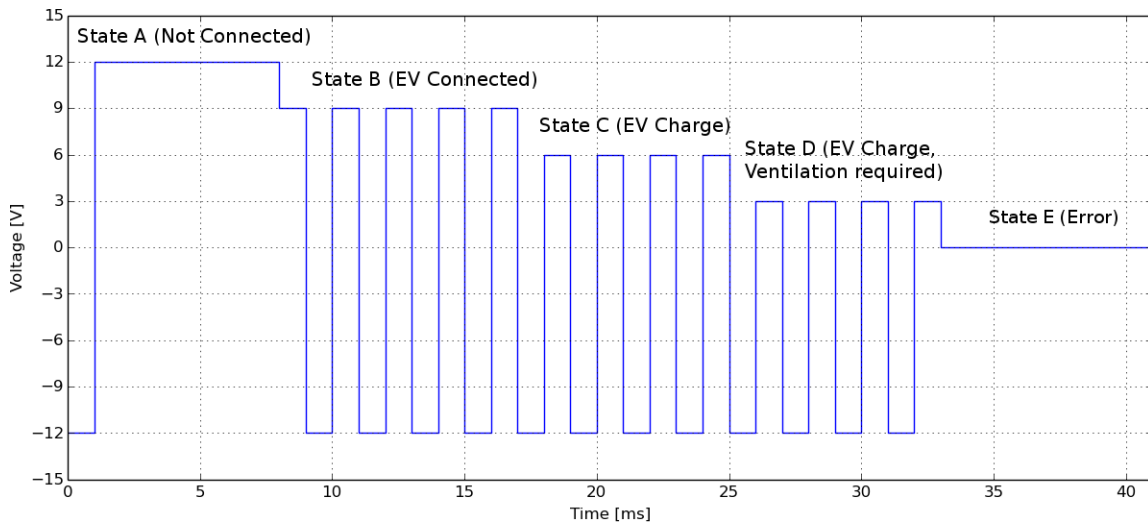

Figure 2.9: J1772 pilot signal states

Once the plug is connected, the charging station induces 12V on the CP, as well as on the PP measuring the voltage differences. It then sends a 1kHz square wave to the CP, which is connected to earthing on the vehicle side. Once the circuit is closed, the EV can request a charging state by setting a resistor between the PP and PE wires. The EVSE analyzes the voltages and adjusts the charging states accordingly. Figure 2.9 and Table 2.4 illustrate this concept.

Table 2.4: EV charging state requests using PWM

State	Pilot High	Pilot Low	Frequency	Resistance	Charging State
State A	+12V	-	DC	-	Not Connected
State B	+9V	-12V	1kHz	2700Ω	EV Connected
State C	+6V	-12V	1kHz	8800Ω	EV Charge
State D	+3V	-12V	1kHz	240Ω	EV Charge (Ventilation required)
State E	+0V	0	-	-	Error
State F	+/-	-12V	-	-	Unknown/Error

The CP-PE loop is permanently connected to a 2700 Ω resistor, which causes the positive voltage of the pilot to drop to +9V when a Mode 3 vehicle is connected to the charging station. Switching the resistance to 880 Ω starts the EV charging process. The positive voltage of the pilot then drops to +6V. And finally, setting the resistance to 240 Ω requests EV charging "with ventilation". Errors can be signaled by setting the pilot voltage to zero. Negative voltages are considered as an error, since the installed diode only causes drops in the positive voltage range.

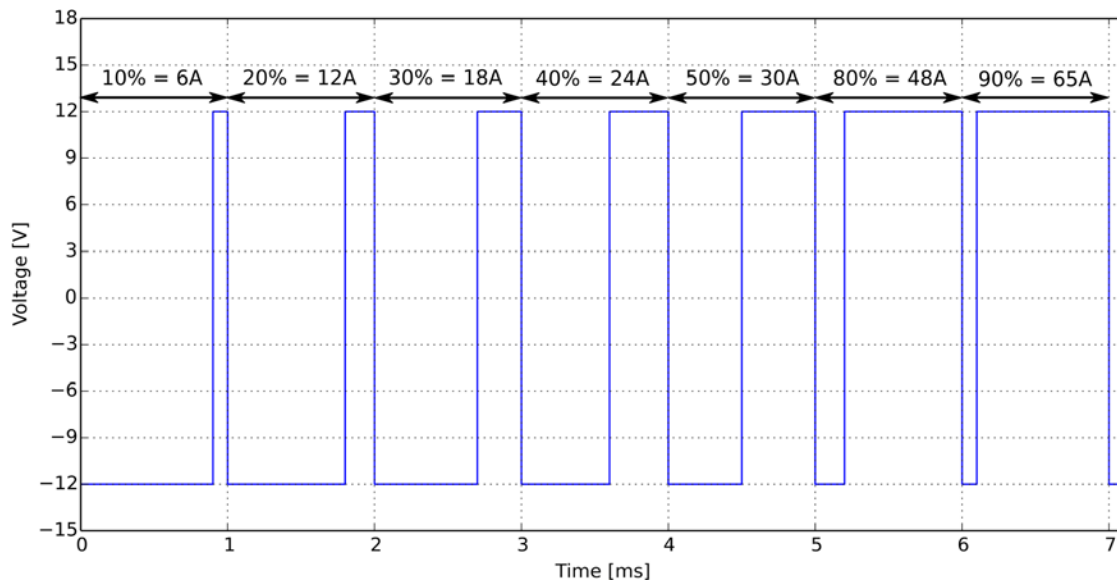

Figure 2.10: Maximum available current determined by pulse width modulation (PWM)

The maximum current that is available from the charging station can be communicated to the EV via pulse width modification (PWM) of the 1kHz square wave of the CP. The EVSE sets the duty cycle, which is defined as the ratio between the high state and the low state. The EV must comply with this setting or change the duty cycle.

The maximum currents for continuous charging are obtained with the following equations:

- **Current from 6A to 51A:** $\text{Current [A]} = \text{Duty Cycle [\%]} * 0.6$
- **Current from 51A to 80A:** $\text{Current [A]} = (\text{Duty Cycle [\%]} - 64) * 2.5$

For example, a 10% duty cycle relates to a maximum current of 10A, a 30% duty cycle is equivalent to 18A, and a 90% duty cycle flags fast charging at 65A.

Table 2.5: EV charging state requests using PWM

Duty Cycle	Current [A]
10%	6A
20%	12A
30%	18A
40%	24A
50%	30A
66%	40A
80%	48A
90%	65A
94%	75A
96%	80A

3.4. Smart Grid EV Communication

The SAE has proposed to utilize power line communication (PLC) between the EV, the off-board charging station, and the smart grid according to the IEEE P1901 standard [28]. This has the advantage that no additional pins would be required. The IEEE P1901 standard specifies high speed communication via electric power lines (up to 500Mbit/s at a frequency below 100MHz). The communication is similar to other 802.x standards. This allows for IP-based communication between the EV, smart grid infrastructure, power meter, building, and other connected appliances. Furthermore, the wireless communications is included.

4. Conclusion

The EV charging station technology and its networks are rapidly evolving. Various public institutions, privately held companies and technical commissions have been developing technical standards, which have yet to be streamlined. This report has introduced key aspects of various national and international EV charging stations standards to determine potentials and limitations on how EV batteries can potentially be utilized to mitigate TOVs. Besides arbitrary time constraints in communication protocols, no technical constraints have been identified. The potential of the EV technology for TOV mitigation is currently being investigated at the University of Hawaii and will be presented in future works.

5. Acknowledgements

This report was funded under a sub-award to the Hawai'i Natural Energy Institute, University of Hawai'i at Manoa, from the Florida Solar Energy Center, University of Central Florida, through a grant from the US Department of Transportation's University Transportation Centers Program, Research and Innovative Technology Administration.

6. References

- [1] S.W. Hadley. Evaluating the impact of plug-in hybrid electric vehicles on regional electricity supplies. In Bulk Power System Dynamics and Control - VII. Revitalizing Operational Reliability, 2007 iREP Symposium, pages 1--12, Aug 2007.
- [2] J.A Peas~Lopes, P.M.R. Almeida, and F.J. Soares. Using vehicle-to-grid to maximize the integration of intermittent renewable energy resources in islanded electric grids. In International Conference on Clean Electrical Power, 2009, pages 290--295, June 2009.
- [3] AY. Saber and G.K. Venayagamoorthy. Plug-in vehicles and renewable energy sources for cost and emission reductions. IEEE Transactions on Industrial Electronics, 58(4):1229--1238, April 2011.
- [4] S. Acha, T.C. Green, and N.Shah. Effects of optimised plug-in hybrid vehicle charging strategies on electric distribution network losses. In Transmission and Distribution Conference and Exposition, 2010 IEEE PES, pages 1--6, April 2010.
- [5] S.G. Wirasingha, N. Schofield, and A Emadi. Plug-in hybrid electric vehicle developments in the US: Trends, barriers, and economic feasibility. In IEEE Vehicle Power and Propulsion Conference, 2008. VPPC '08, pages 1--8, Sept 2008.
- [6] M. Caramanis and J.M. Foster. Management of electric vehicle charging to mitigate renewable generation intermittency and distribution network congestion. In Decision and Control, 2009 held jointly with the 2009 28th Chinese Control Conference. CDC/CCC 2009. Proceedings of the 48th IEEE Conference on Control, pages 4717--4722, Dec 2009.
- [7] J. AP. Lopes, F.J. Soares, and P.M.R. Almeida. Integration of electric vehicles in the electric power system. Proceedings of the IEEE, 99(1):168--183, Jan 2011.
- [8] Zhenpo Wang and Shuo Wang. Grid power peak shaving and valley filling using vehicle-to-grid systems. IEEE Transactions on Power Delivery, 28(3):1822--1829, July 2013.
- [9] N. Chen, C. Tan, and T. Quek. Electric vehicle charging in smart grid: Optimality and valley-filling algorithms. IEEE Journal of Selected Topics in Signal Processing, PP(99):1-1, 2014.

- [10] Hawaiian Electric Company. Transient over-voltage mitigation: Explanation and mitigation options for inverter-based distributed generation projects < 10kw. Technical report, 2014.
- [11] M.J. Reno, R.J. Broderick, and S. Grijalva. Smart inverter capabilities for mitigating over-voltage on distribution systems with high penetrations of PV. In Photovoltaic Specialists Conference (PVSC), 2013 IEEE 39th, pages 3153--3158, June 2013.
- [12] J.W. Smith, W. Sunderman, R. Dugan, and B. Seal. Smart inverter Volt/Var control functions for high penetration of PV on distribution systems. In IEEE/PES Power Systems Conference and Exposition (PSCE), pages 1--6, March 2011.
- [13] J. Smith. Modeling high-penetration PV for distribution interconnection studies. Technical report, 2013.
- [14] T. Niknam, AM. Ranjbar, and A. R. Shirani. Impact of distributed generation on Volt/Var control in distribution networks. In Power Tech Conference Proceedings, 2003 IEEE Bologna, volume 3, pages 7 pp. Vol.3--, June 2003.
- [15] M.J. Hossain, T.K. Saha, N. Mithulananthan, and H.R. Pota. Robust control strategy for PV system integration in distribution systems. *Applied Energy*, 99(C):355--362, 2012.
- [16] Huijuan Li, Yan Xu, S. Adhikari, D.T. Rizy, Fangxing Li, and P. Irminger. Real and reactive power control of a three-phase single-stage PV system and PV voltage stability.
- [17] Masato Oshiro, Kenichi Tanaka, Tomonobu Senjyu, Shohei Toma, Atsushi Yona, Ashmed~Yousuf Saber, Toshihisa Funabashi, and Chul-Hwan Kim. Optimal voltage control in distribution systems using PV generators. *International Journal of Electrical Power & Energy Systems*, 33(3):485 -- 492, 2011.
- [18] Konstantin Turitsyn, Petr Sulc, Scott Backhaus, and Michael Chertkov. Distributed control of reactive power flow in a radial distribution circuit with high photovoltaic penetration. In *Proceedings of IEEE PES General Meeting 2010*, 2010.
- [19] Craig B. Toepfer. SAE electric vehicle and plug in hybrid electric vehicle conductive charge coupler., August 2001.
- [20] Plug-In America. Hawaii EV ready - guidebook for commercial electric vehicle charging station installations. Technical report, Plug In America, 2012.
- [21] Barrie Lawson. Electric vehicle charging infrastructure, Technical Report.
- [22] IEC 61851-1: Charging of electric vehicles up to 250 AC and 400 DC
- [23] Siemens. www.siemens.com. Charging modes for electric vehicles.
- [24] IEC 60309-1: Plugs, socket-outlets and couplers for industrial purposes. General requirements, 2012.

[25] Mennekes. The solution for Europe: Type 2 charging socket with or without shutter.